



WATERFLOW DETECTOR

Waterflow Detector U Bolted / Model WFD



Features

- UL-listed models are NEMA 4 rated
- The WFD series is compatible with schedule 10 through 40 steel pipe, sizes 2" through 8", and can be mounted in a vertical or horizontal position.
- Sealed retard mechanism immune to dust and other contaminants
- Visual switch activation
- Field-replaceable retard mechanism and SPDT switches
- Rugged, dual SPDT switches enclosed in a durable terminal block
- Accommodates up to 12 AWG wire
- Designed for both indoor and outdoor use
- 100 percent synchronization activates both alarm panel and local bell
- Tamper-resistant cover screws

Robust Construction. The WFD series consists of a rugged, NEMA 4-rated enclosure. Designed for both indoor and outdoor use, the WFD series operates across a wide temperature range, from 32°F to 120°F.

Reliable Performance. UL-listed models are equipped with tamper-resistant cover screws to prevent unauthorized entry. Inside, two sets of SPDT (Form C) synchronized switches are enclosed in a durable terminal block to assure reliable performance.

False Alarm Immunity. The WFD series incorporates a mechanical retard feature, which minimizes the risk of false alarm due to pressure surges or air trapped in the sprinkler system. In addition, the mechanical retard's unique sealed design is immune to dust and other contaminants.

Simplified Operation. The WFD series is designed to simplify installation. Two conduit openings permit easy attachment to the local alarm system. The retard mechanism and dual SPDT switches are field-replaceable.

Specifications

Static Pressure Rating	: 450 PSI*
Maximum Surge	: 18 FPS
Triggering Threshold Bandwidth (Flow Rate)	: 4–10 GPM
Conduit Entrances	: Two openings for ½" conduit. One open, one knock-out type
Contact Ratings	: Two sets of SPDT (Form C) — 10.0 A @ 125/250 VAC — 2.5 A @ 24 VDC
Compatible Pipe	: Steel water pipe, schedule 10 through 40
Operating Temperature Range	: 32°F to 120°F (0°C to 49°C)
Enclosure Rating*	: NEMA4 - Suitable for indoor/outdoor use
Cover Tamper Switch	: Standard with ULC models, optional for UL models, part no. 546-7000
Service Use	: Automatic Sprinkler: NFPA 13 One or Two Family Dwelling: NFPA 13D Residential Occupancies up to 4 Stories: NFPA 13R National Fire Alarm Code: NFPA 72

WATERFLOW DETECTOR

Wiring Diagram

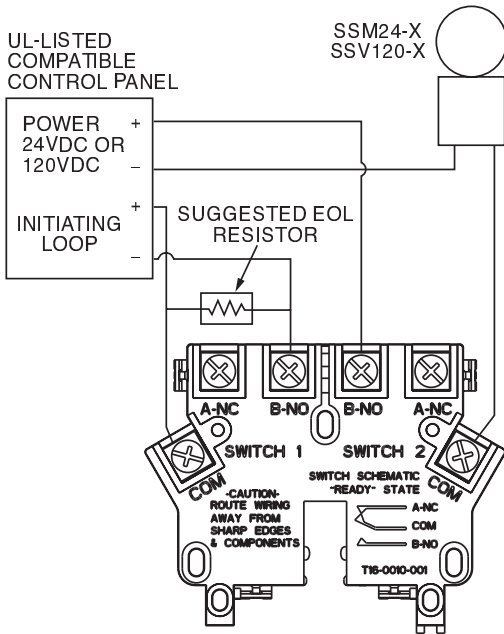

NOTE: COMMON AND B-NO CONNECTIONS WILL CLOSE WHEN VANE IS DEFLECTED, I.E., WHEN WATER IS FLOWING. DUAL SWITCHES PERMIT APPLICATIONS TO BE COMBINED ON A SINGLE DETECTOR.

CONTACT RATINGS	
125/250 VAC	10 AMPS
24 VDC	2.5 AMPS

SCHEMATIC OF INDIVIDUAL SWITCH IN "NO WATERFLOW" CONDITION

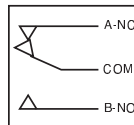

BREAK WIRE AS SHOWN FOR SUPERVISION OF CONNECTION. DO NOT ALLOW STRIPPED WIRE LEADS TO EXTEND BEYOND SWITCH HOUSING. DO NOT LOOP WIRES.

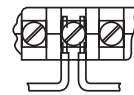

Delay Adjustment Dial

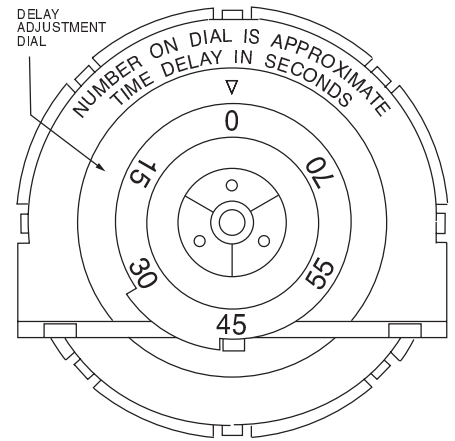

NOTE: RETARD TIME MAY EXCEED 90 SECONDS. ADJUST AND VERIFY THAT TIME DOES NOT EXCEED 90 SECONDS. NUMBER ON DIAL IS APPROXIMATE TIME DELAY IN SECONDS WITH AN ACCURACY OF +/- 50%.

Dimensions

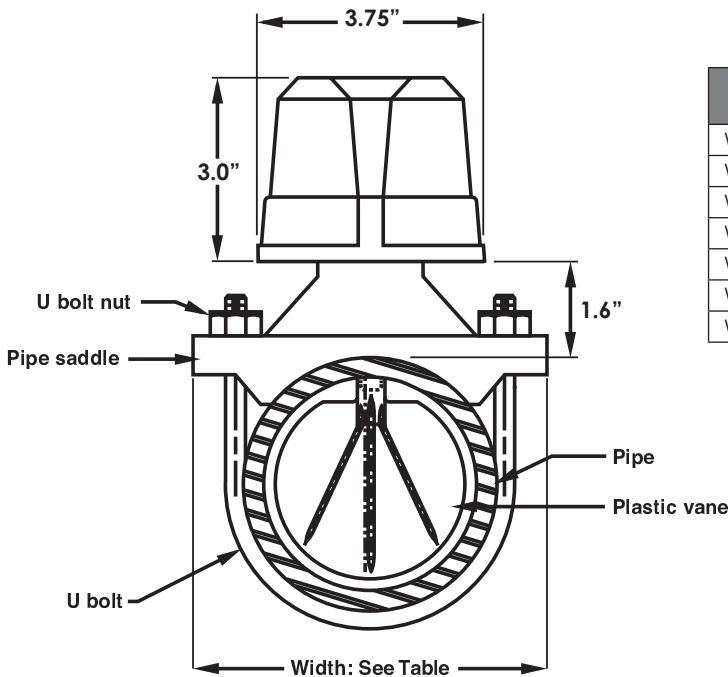

Model	Pipe Size (inch)	Hole Size (inch)	Width (inch)	Weight (kg)
WFD20	2"	1 1/4"	4,6"	1,9
WFD25	2 1/2"	1 1/4"	4,6"	1,95
WFD30-2	3"	2"	5,2"	2,04
WFD40	4"	2"	5,7"	2,36
WFD50	5"	2"	6,8"	2,86
WFD60	6"	2"	9,0"	3,08
WFD80	8"	2"	10,8"	3,4